

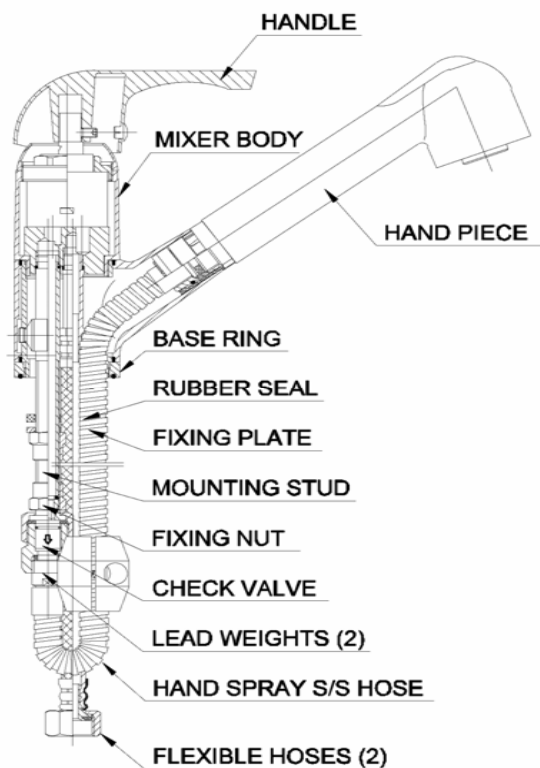

40mm VEGE SPRAY MIXER

Congratulations for purchasing this quality Ewing Vege Spray Mixer.



Installation Instructions.

This Vege spray mixer is already factory assembled and designed for easy installation and maintenance.

Please follow these instructions:

1. Place the O-ring on the underside of the vege spray. Connect the flexible hoses (2) firmly onto the extended connectors of the vege spray.
2. Insert the hand spray tail into the handle section of the swivel arm.
3. Place the vege spray into the pre-punched hole in the sink, with the flexible hoses and hand spray hose going in first.
4. From underneath the sink, fix the base washer, fixing plate and fixing nut in the respective order.
5. Tighten the fixing nut with a tube spanner to clamp the mixer firmly onto the sink.
6. Fix the lead weights (2) onto the hand spray hose so it can pull down the hand spray back to the resting position of the swivel arm.
7. Connect the hand spray hose to the fixing bolt via a two-way flexible hose, avoiding any tangling of the hand spray hose. The hose assembly and union contains the Non Return Check Valve.
8. FLUSH THE TWO PIPELINES TO CLEAR ANY RUBBISH. Connect the mixer to the water supply line by connecting the two flexible connectors to the already installed isolating cocks.

IMPORTANT NOTE:

The union nuts on the hose must be connected to fittings which have machined end faces, NOT sawn off threaded tube.

We do not recommend dismantling the internal parts of the mixer. The mixers are individually factory assembled and tested to give the best performance.

For after Sales and Service in Australia
 Phone: 1800 135 906
 Fax: 07 3205 6905
 PLEASE RETAIN YOUR PROOF OF PURCHASE

Warranty.

Thank you for choosing a quality Ewing Product that is manufactured to Australian Standards Requirements. Ewing Tapware (where applicable) has been rated under the Water Efficiency Labelling Scheme (WELS), our WELS licence number is 0037.

Technical Information

- ◆ Hot and Cold water inlet pressures should be equal.
- ◆ Inlet pressure must not exceed 500kPa.
- ◆ Minimum operating pressure of 150kPa is required.
- ◆ Maximum hot water temperature 80 degrees Celsius.
- ◆ Not suitable for gravity feed systems

Terms and Conditions.

Ewing Industries undertakes to repair, or at its option replace only, any product, which is defective through faulty workmanship or materials within 12 months of the purchase of the goods. A further four years 'parts only' warranty is given on the ceramic disc cartridge

The warranty period commences from the date of purchase.

Ewing Industries reserves the right to provide components as 'parts only' to the customer. This warranty is only applicable for products purchased from an authorised Ewing Industries reseller. The labour component of the warranty does not cover excessive time taken to access or remove the product from its installed location. The warranty is limited to Ewing Industries products only and does not cover other manufactures products, which may be attached to Ewing Industries products.

Warranty may be void due to the following reasons :-

- ◆ Inability to provide proof of purchase.
- ◆ Products are not installed by a licensed plumber or in accordance with relevant industry standards or regulations.
- ◆ The product is exposed to water pressures that are greater than 500kPa and temperatures exceed 80 degrees Celsius.
- ◆ Products used for incorrect applications and in inappropriate locations.
- ◆ Products are cleaned with anything other than a soft cloth soaked with warm water. The use of abrasive cleaners or harsh detergents may void the warranty

Care and Cleaning.

Clean regularly with warm water and a soft cloth
 Do not use abrasive cleaners or harsh detergents.